

Operating and Evaluating Quadrature Modulators for Personal Communication Systems

National Semiconductor
 Application Note 899
 Ruth Umstadd
 Wireless Communications
 October 1993



Operating and Evaluating Quadrature Modulators for Personal Communication Systems

ABSTRACT

The quadrature modulator is a fundamental radio component for worldwide digital wireless communication standards such as Global System for Mobile Communications (GSM), Digital Communications Systems—1800 MHz (DCS1800), Digital European Cordless Telecommunications (DECT), American and Personal Digital Cellular (ADC/PDC), Japanese Personal Handy Phone (PHP RCR28). A typical system application and the theory of operation of the quadrature modulator are described along with two practical evaluation methods. Radio system considerations are discussed for the quadrature modulator including phase and amplitude imbalances, DC offsets, time dependent phase errors, modulated carrier harmonics, and nonlinear impairments.

INTRODUCTION

Worldwide standards for the mobile communications environment are demanding spectrally efficient digital modulation techniques. Low power, low cost, integrated quadrature modulators can be used in wireless personal communications for digital modulation (i.e., QPSK (Quadrature Phase Shift Keying), $\pi/4$ DQPSK (Pi over 4 Differential Quadrature Phase Shift Keying), MSK (Minimum Shift Keying), GMSK (Gaussian filtered Minimum Shift Keying)). The quadrature modulator has the advantage that any parameter of a carrier frequency (amplitude, phase, or frequency) can be simultaneously manipulated to represent information. Other modulators do not have this flexibility. For example, a single mixer can be used to modulate a carrier. In this case, an information signal is limited to modulating a carrier by altering its amplitude (or phase by 180°) or its frequency. *Figure 1* illustrates a mixer performing a simple digital modulation technique, binary phase shift keying (BPSK), that consists of shifting the phase of a carrier by 180° (or changing the amplitude of a carrier between a positive and a negative state). The result is two information states; where one could represent bit 0 and the other state could represent bit 1. The constellation diagram of *Figure 1* illustrates the two states along one axis.

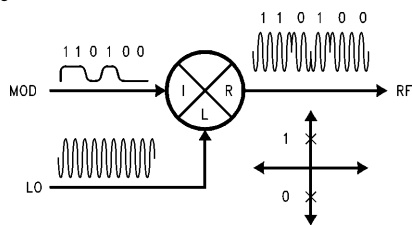
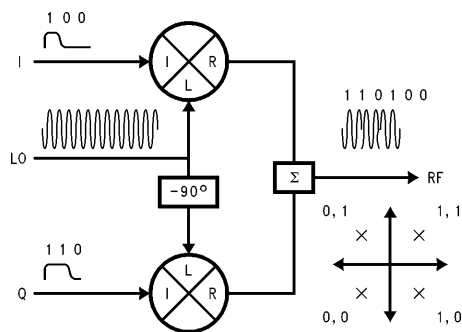

FIGURE 1. Mixer Performing BPSK

TL/W/11877-1

In comparison, for a quadrature modulator information is modulated onto a carrier with full freedom to manipulate the amplitude, phase, or frequency of the carrier. A quadrature modulator is implemented with a phase shifter, two mixers, and a signal combining stage. *Figure 2* shows a quadrature modulator performing QPSK.



TL/W/11877-2

FIGURE 2. Quadrature Modulator Performing QPSK

Even bits of the information signal are directed to one mixer and the odd bits are directed to the second mixer. The LO is shifted by 90° at one mixer. For QPSK, the result at the output of the modulator is four states of information where each state represents two bits. Compared to *Figure 1*, the quadrature modulator transmits the same information in half the time. QPSK is only one modulation scheme that can be employed by the quadrature modulator. The information bearing signal inputs can vary so that a vector from the origin of the constellation diagram can have any amplitude and phase value at any point in time. The quadrature modulator is a flexible modulator that is used with spectrally efficient modulation schemes.

Historically, a discrete version of the quadrature modulator has been used in sophisticated communication systems. Currently, the cellular and cordless telephony market demands an integrated quadrature modulator suitable for high volume production. In this document, the description, operation, and evaluation of the quadrature modulator is given from the current commercial applications perspective.

TYPICAL SYSTEM APPLICATION

The quadrature modulator provides the necessary interface between digital data and the RF transmission channel. *Figure 3* shows a typical transmit system block diagram using a direct conversion quadrature modulator.

AN-899

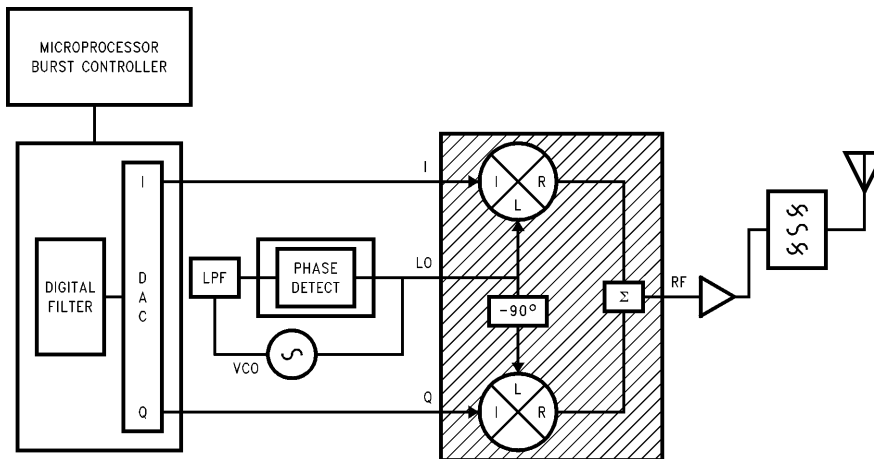

TL/W/11877-3

FIGURE 3. Transmit System Block Diagram

A stream of information from the microprocessor is compressed and sent in bursts by the burst mode controller to the baseband processor. The baseband processor mathematically manipulates the signal using a digital filter and a digital to analog converter (DAC) to generate the in-phase signal $i(t)$ and quadrature signal $q(t)$ for the modulating inputs of the quadrature modulator. The local oscillator (LO) input to the modulator is supplied by a frequency synthesizer that is composed of a phase detector, a low pass filter, and a tunable VCO. The frequency of the LO or carrier changes depending on the selected transmit channel. The output of the modulator, the carrier frequency modulated by the $i(t)$ and $q(t)$ signals, is amplified by a power amplifier, filtered and then radiated through an external antenna.

THEORY OF OPERATION

A typical monolithic implementation of a quadrature modulator consists of two multipliers and a signal combining amplifier stage. Each of the multipliers is provided an LO and a modulating signal. One of the LO signals is shifted by 90° with respect to the other LO signal at the inputs of the two multipliers. The information signals $i(t)$ and $q(t)$ are each mixed with one of the LO signals. The output signals of the two multipliers are combined and amplified. Equation (1) describes the modulated output of an ideal quadrature modulator where $i(t)$ is the in phase information signal, $q(t)$ is the quadrature information signal, $\cos(\omega_c t)$ is the LO signal for one mixer, $\sin(\omega_c t)$ is the LO signal for the other mixer (Note 1), and k is a constant gain or loss.

$$v(t) = k [i(t) \cos(\omega_c t) + q(t) \sin(\omega_c t)] \quad (1)$$

Note 1: The LO signal is modeled as a sinusoidal signal for the sake of simple mathematical demonstration. The quadrature modulator limits the LO signal making a square wave representation of the LO more precise.

This equation can be written in phasor format:

$$v(t) = k a(t) \cos[\omega_c t - \varphi(t)] \quad (2)$$

where:

$$a(t) = \sqrt{i^2(t) + q^2(t)} \quad (3)$$

$$\varphi(t) = \tan^{-1} [q(t)/i(t)] \quad (4)$$

Figures 4, 5, and 6 are examples of three quadrature modulation schemes: QPSK, $\pi/4$ DQPSK, and GMSK. The $i(t)$, $q(t)$, the eye diagrams of $i(t)$ and $q(t)$, the frequency spectrum, and the constellation for each modulation scheme is shown. All of these signals are plotted on the same time or frequency scale for the sake of comparison. Sections a) through d) of Figures 4 and 5 have a voltage by symbol time reference. Sections a) through d) of Figure 6 have a voltage by bit time reference. The dashed lines in the constellation diagrams represent state transitions.

A raised cosine filter is used to shape the modulating signals before they enter the quadrature modulator. This reduces the bandwidth of the modulated signal out of the quadrature modulator. A baseband processor is responsible for this filtering not the quadrature modulator. For the sake of understanding the input modulating signals, the equation for this filter is shown below where T is the bit time normalized to 1 and α , the filter roll-off, is equal to 0.5 [2].

$$h(t) = \frac{\sin(\pi t/T)}{\pi t/T} \frac{\cos(\pi \alpha t/T)}{1 - 4(\alpha t/T)^2} \quad (5)$$

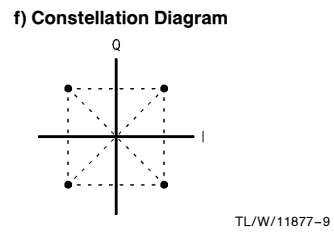
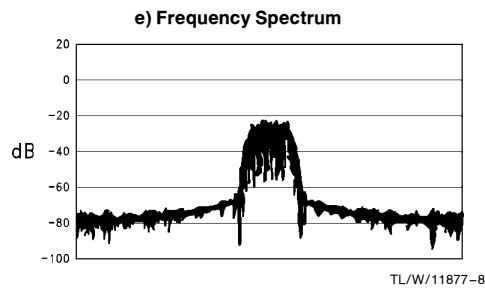
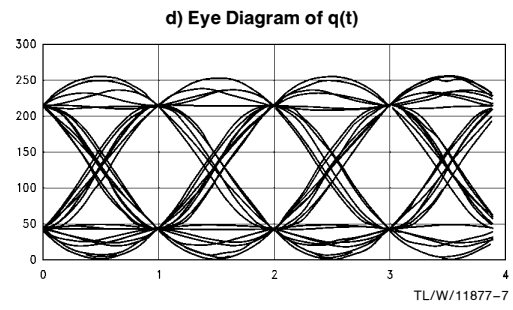
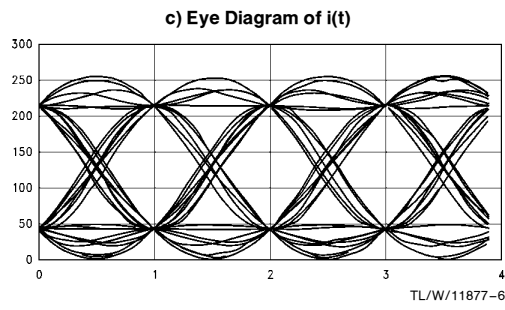
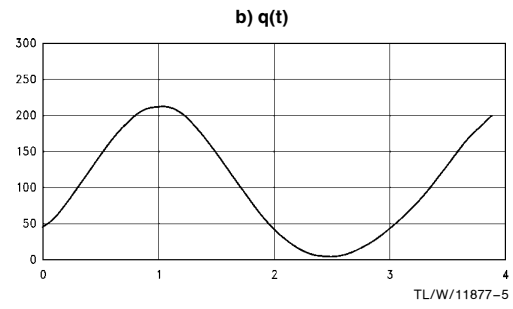
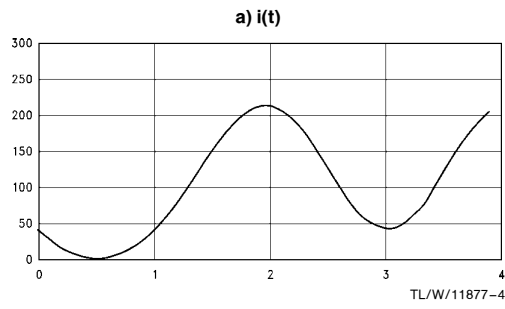

FIGURE 4. QPSK Modulation

A raised cosine filter (Equation (5)) is also used to shape the modulating signals in *Figure 5*, a $\pi/4$ DQPSK modulation scheme. The modulating signals are differentially encoded and prevent factors of a 90° state transition. The spectral

efficiency of $\pi/4$ DQPSK compared to QPSK is the same. The advantage of $\pi/4$ DQPSK over QPSK is that it reduces the amplitude modulation of the modulated signal by preventing a zero crossing in the constellation.

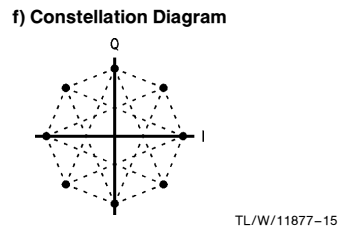
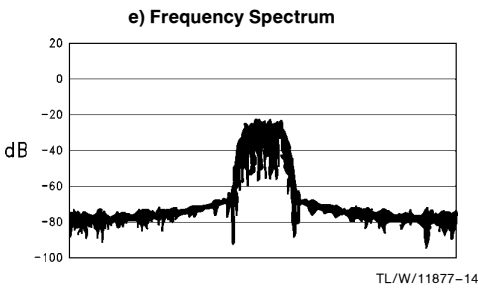
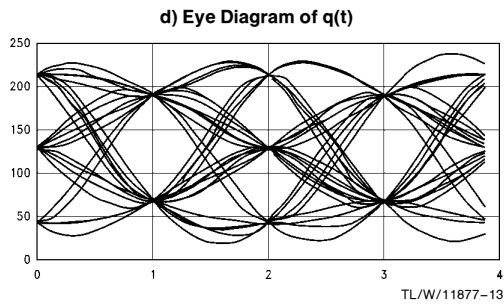
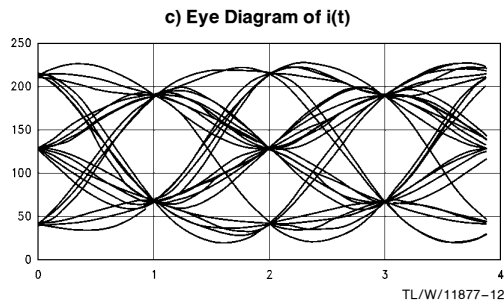
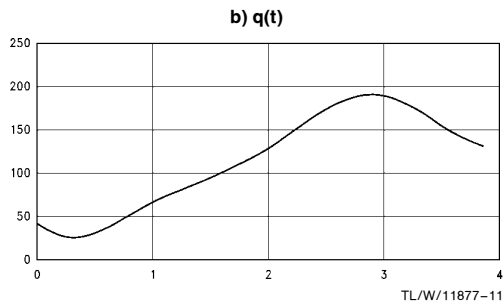
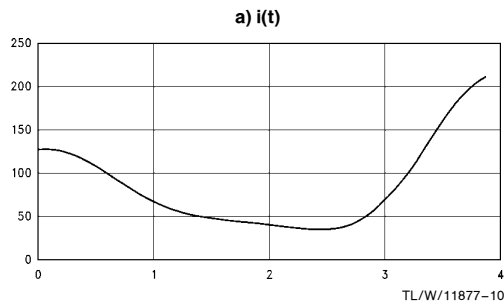

FIGURE 5. $\pi/4$ DQPSK Modulation

The modulating signals shown in *Figure 6* are Gaussian filtered. The equation used for the Gaussian filter, normalized to a bit time (T) equal to 1, is given below [2]:

$$h(t) = B \sqrt{\frac{2\pi}{\ln(2)}} \cdot e^{-\frac{2(Bt\pi)^2}{\ln(2)}} \quad (6)$$

GMSK is less spectrally efficient compared to QPSK or $\pi/4$ DQPSK. The advantage is seen in the constellation diagram. GMSK is strictly frequency modulation; there is no amplitude modulation in a perfect GMSK signal.

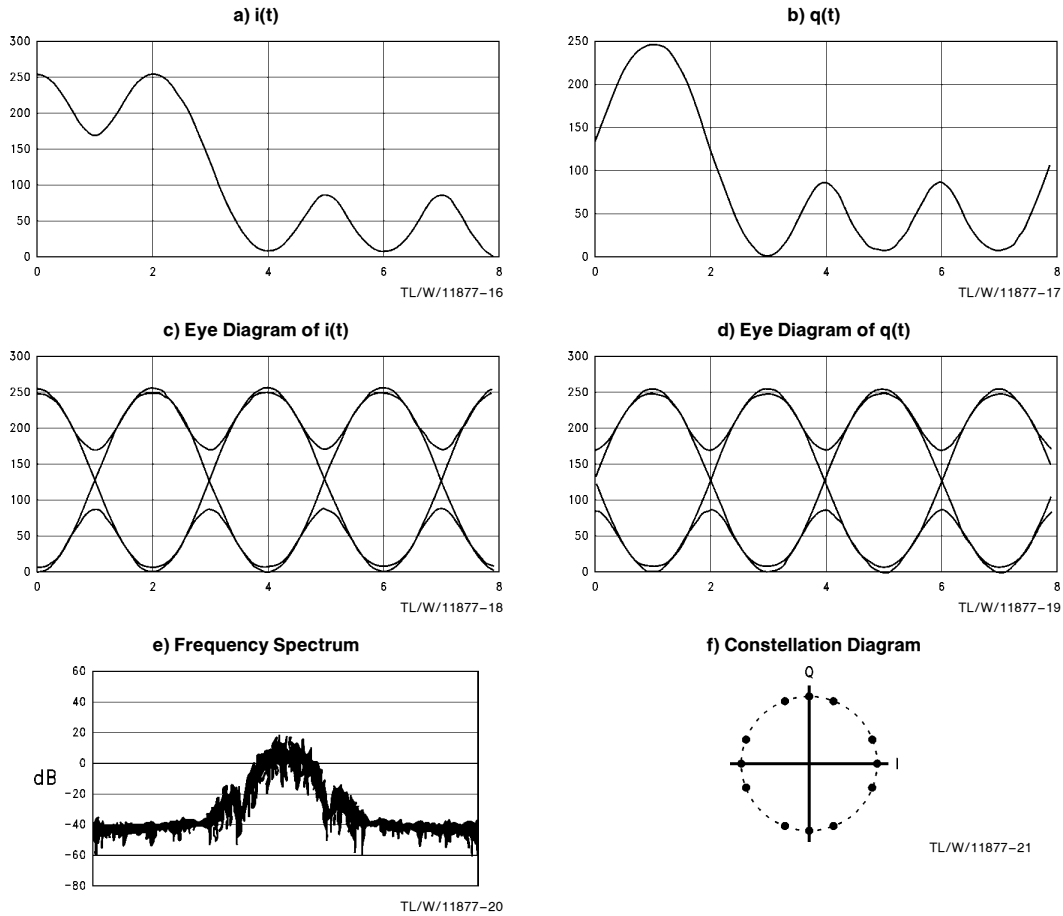

FIGURE 6. GMSK Modulation

EVALUATING QUADRATURE MODULATORS

For digital radios, an evaluation system for the quadrature modulator would contain the following: a modulating signal source that would generate the desired modulation scheme, a local oscillator with, if needed, a highly accurate phase shifter and power splitter, and an accurate demodulator that would provide symbol error ratio (SER) results. Current test and measurement equipment does not support a practical solution for high volume production test of SER. Instead the quadrature modulator is evaluated based on equations (1) and (2). This provides the freedom of evaluating the amplitude and phase response of the quadrature modulator for a variety of modulating input signals.

STATIC MODULATING SIGNAL EVALUATION

One evaluation method for the quadrature modulator is to use a vector network analyzer in conjunction with DC voltages as the modulating input to generate phasor information at the output of the modulator. *Figure 7* describes the necessary setup.

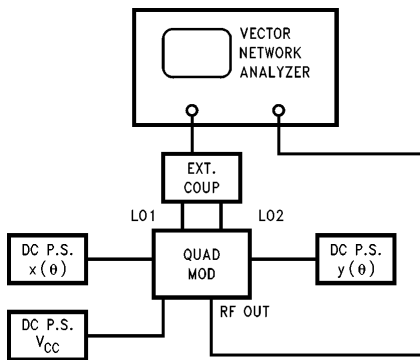

TL/W/11877-22

FIGURE 7. DC Static Test Setup

A vector network analyzer is set up in a continuous wave mode to provide the LO source for the modulator. An external coupler is used to split and phase shift the LO signals for the inputs of the modulator. (If the quadrature modulator has an on board phase shifter, the external coupler is not necessary). The output of the modulator is connected to the second port of the network analyzer. The network analyzer is set up for polar output of the forward transducer gain. Manually changing the DC signals at the modulating input ports rotates an information vector through the different quadrants on the polar output of the network analyzer. The DC voltage at the modulating input ports is the in-phase or quadrature signal plus the necessary offset voltage V_{REF} .

$$x(\theta) = i(\theta) + V_{REF} \quad (7)$$

$$y(\theta) = q(\theta) + V_{REF} \quad (8)$$

One way to approach the choice of DC signal inputs is to make instantaneous measurements that reflect the modulation scheme chosen for an application. For example, GMSK is a constant envelope, frequency modulation scheme. This translates by equation (2) to a vector with $a(t)$ having a constant amplitude and $\varphi(t)$ rotating at the modulating frequency rate (or $1/4$ the bit rate). In this DC static test case, $\varphi(t)$ is not a function of time. Instead this angle is determined by $\tan^{-1}[q(\theta)/i(\theta)]$. In order for $a(\theta)$ to have a constant amplitude and $\varphi(\theta)$ to have a known angle, $q(\theta)$ and $i(\theta)$ can take on the following instantaneous values:

$$i(\theta) = V_m \cos \theta \quad (9)$$

$$q(\theta) = V_m \sin \theta \quad (10)$$

where V_m is the peak to peak modulating voltage and θ is the variable angle of the phasor both of which are determined by the user. Using equations (2), (3), and (4),

$$a(\theta) = V_m \quad (11)$$

$$\varphi(\theta) = \theta \quad (12)$$

$$v(t, \theta) = k V_m \cos(\omega_c t - \theta) \quad (13)$$

This allows for making discrete measurements of the points identified by the phasor at a predetermined angle. If the quadrature modulator is ideal and the input signals are accurate, the measurement points identify the trace of a perfect circle. Error terms like amplitude imbalance, phase imbalance, carrier leakage distort the circle in linear and non-linear fashions. The data taken from a quadrature modulator using a static modulating signal evaluation can be manipulated to predict frequency spectrum characteristics. An analysis of these error terms and the resulting effects are given in the system considerations section of this document. The single sideband up-conversion evaluation of the quadrature modulator is necessary to circumvent the mathematics of determining the frequency spectrum.

SSB UP-CONVERSION EVALUATION

The single sideband (SSB) up conversion test is currently the most widely used evaluation method for the integrated quadrature modulator. The implementation of this measurement can be done with a frequency synthesizer (for the LO source), a spectrum analyzer, a dual arbitrary waveform generator (for $i(t)$ and $q(t)$), and an external coupler (if needed) for the LO phase shift and power split. *Figure 8* illustrates the setup.

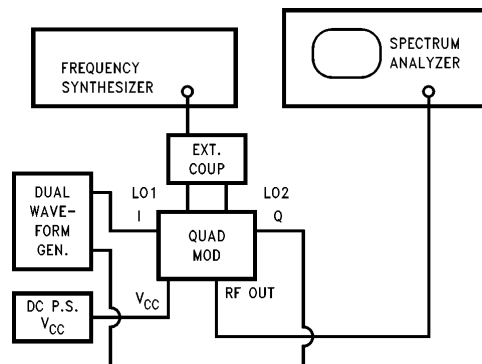

TL/W/11877-23

FIGURE 8. SSB Test Setup

In theory, this test is very much like the static modulating signal test except that the modulating signals are sinusoids:

$$i(t) = V_m \cos(\omega_m t) \quad (14)$$

$$q(t) = V_m \sin(\omega_m t) \quad (15)$$

Using equations (2), (3), and (4),

$$a(t) = V_m \quad (16)$$

$$\varphi(t) = \omega_m t \quad (17)$$

$$v(t) = k V_m \cos(\omega_c t - \omega_m t) \quad (18)$$

Using equation (1),

$$v(t) = k V_m \cos(\omega_m t) \cos(\omega_c t) + k V_m \sin(\omega_m t) \sin(\omega_c t) \quad (19)$$

$$v(t) = \frac{1}{2} k V_m \left[\cos(\omega_c - \omega_m)t + \cos(\omega_c + \omega_m)t + \cos(\omega_c - \omega_m)t - \cos(\omega_c + \omega_m)t \right] \quad (20)$$

which can be reduced to:

$$v(t) = k V_m \cos((\omega_c - \omega_m)t) \quad (21)$$

For an ideal quadrature modulator, the output for this SSB evaluation in the positive frequency spectrum would be a

discrete frequency at $f_c - f_m$. The location of this impulse can be changed to $f_c + f_m$ by reversing the phase shift at either the LO ports or the modulating ports.

The modulating frequency for an SSB test is chosen to represent the peak frequency deviation of a given application. For example, the bit rate of a GMSK signal for GSM is 270.8 kb/s. In this minimum shift keying (MSK) case, the peak frequency deviation is one quarter the bit rate [5]. The choice of modulating frequency for an SSB test for GSM is 67.7 kHz.

When making SSB measurements of an actual quadrature modulator, the carrier, the undesired sideband, up-converted modulating signal harmonics, and harmonics of the modulated carrier are present in the frequency spectrum along with the desired sideband. *Figure 6* is an example of SSB test data of a quadrature modulator. (Note 2)

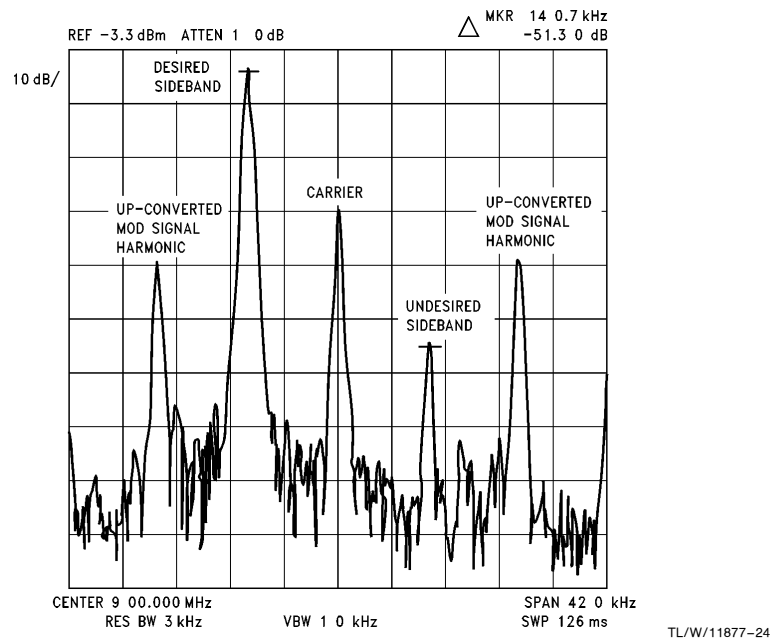

FIGURE 9. SSB Test Data

Single sideband test data of a quadrature modulator includes traces of the undesired sideband, the carrier, up-converted modulating signal harmonics, and modulated carrier harmonics. All of these terms are of critical interest to the radio system designer. They can be correlated to symbol error rate and adjacent channel interference. The sources of performance degradation and features of the quadrature modulator that must be addressed in a radio system design are discussed in the following sections.

Note 2: The harmonics of the modulated carrier are outside the frequency span of this plot.

SYSTEM CONSIDERATIONS

The performance of the quadrature modulator is a function of the accuracy of the quadrature modulator and the accuracy of the input signals. Imperfections in the input signals and the quadrature modulator result in vector state amplitude error resulting in unwanted envelope fluctuations, vector state phase error that inhibit optimal demodulating sampling time, and unfilterable out of band signals that may interfere with other channels. The sources and affects of linear errors, slew rate limitations, modulated carrier harmonics, and nonlinear impairments are shown for the quadrature modulator.

Linear Errors

Sources of linear error consist of phase imbalance, amplitude imbalance, and DC offsets associated with the carrier signal and the modulating signal. Each of these terms is discussed and included in an equation to model the effects of these error terms.

There are two different phase errors to model that are introduced either by the user's signal input or by the quadrature modulator. One phase error is introduced by imperfect quadrature at the LO signal. This term is fixed at a given carrier frequency and carrier power unless the quadrature modulator has an LO phase adjust. The second phase error is introduced at the modulating signals. During a SSB test, the modulating signal phase error is controlled by the user. For ideal operation, the quadrature modulating signals is shifted by 90° with respect to the in phase signal.

Amplitude imbalances are associated with the two LO signal inputs and the two modulating signal inputs. Ideally, the two LO signals are equal in amplitude and the two modulating signals are equal in amplitude. The amplitude balance of the two LO signals is far less critical than the balance of the two modulating signals. (The LO signals operate transistors as switches in the modulator while the modulating signals operate transistors in a linear fashion.)

DC offsets are introduced in both the LO signals and the modulating signals. For integrated applications, the LO signal DC reference is set internally and the modulating signal DC reference is set externally. DC offsets arise from improper supply of the DC reference and mismatch in transistors internal to the quadrature modulator. The effect of a DC offset is modeled as a ratio of the offset over the peak-to-peak voltage swing. In an ideal case, this ratio is equal to zero.

Equation (22) combines phase error, amplitude imbalance, and DC offset errors into Equation (19) to predict vector state amplitude error, vector state phase error, undesired sideband suppression, and carrier suppression. The carrier phase error is α . The modulating phase error is β . The carrier amplitude balance ratio is K_c . The modulating signal amplitude balance ratio is K_m . The DC offset divided by the peak-to-peak voltage swing at the carrier is D_c . The DC offset divided by the peak-to-peak voltage swing at the modulating signal is D_m . The error terms, K_c , K_m , α , and β , are lumped into half of the Equation (19) since they are relative to the other half of the equation. The DC offset terms are independent so D_c and D_m are divided into D_{c1} , D_{c2} and D_{m1} , D_{m2} .

$$v(t) = k V_m \begin{bmatrix} K_c K_m [\sin(\omega_c t + \alpha) + D_{c1}] [\sin(\omega_m t + \beta) + D_{m1}] \\ + [\cos(\omega_c t) + D_{c2}] [\cos(\omega_m t) + D_{m2}] \end{bmatrix} \quad (22)$$

This equation is expanded and then reduced to see the converted frequency terms.

$$v(t) = \begin{bmatrix} \frac{1}{2} \cos(\omega_c t + \omega_m t) (1 - K_m K_c \cos(\alpha + \beta)) \\ + \frac{1}{2} \cos(\omega_c t - \omega_m t) (1 + K_m K_c \cos(\alpha - \beta)) \\ + \frac{1}{2} \sin(\omega_c t + \omega_m t) (K_m K_c \sin(\alpha + \beta)) \\ - \frac{1}{2} \sin(\omega_c t - \omega_m t) (K_m K_c \sin(\alpha - \beta)) \\ + K_m K_c D_{c1} \sin(\omega_m t) \cos \beta \\ + K_m K_c D_{c1} \cos(\omega_m t) \sin \beta \\ + D_{c2} \cos(\omega_m t) \\ + K_m K_c D_{m1} \sin(\omega_c t) \cos \alpha \\ + K_m K_c D_{m1} \cos(\omega_c t) \sin \alpha \\ + D_{m2} \cos(\omega_c t) \\ + K_m K_c D_{m1} D_{c1} \\ + D_{m2} D_{c2} \end{bmatrix} \quad (23)$$

The desired sideband term is a function of $\omega_c - \omega_m$. The vector state amplitude error (in dB) and the vector state phase error (in degrees) of the desired sideband are given in Equations (24) and (25).

$$a(t)_{\text{error}} = 10 \log \left(\frac{1}{2} \left(1 + 2 K_m K_c \cos(\alpha - \beta) + K_m^2 K_c^2 \right) \right) \quad (24)$$

$$\varphi(t)_{\text{error}} = \tan^{-1} \left[\frac{-K_m K_c \sin(\alpha - \beta)}{1 + K_m K_c \cos(\alpha - \beta)} \right] \quad (25)$$

Equations (26) and (27) demonstrate the effects of these error terms on sideband suppression and carrier suppression (both in dB) [3].

Sideband

$$\text{Suppression} = 10 \log \left[\frac{1 - 2K_m K_c \cos(\alpha + \beta) + K_m^2 K_c^2}{1 + 2K_m K_c \cos(\alpha - \beta) + K_m^2 K_c^2} \right] \quad (26)$$

Carrier

$$\text{Suppression} = 10 \log \left[\frac{D_{m2}^2 + 2K_m K_c D_{m1} \sin \alpha + K_m^2 K_c^2 D_{m1}^2}{\frac{1}{2} (1 + 2K_m K_c \cos(\alpha - \beta) + K_m^2 K_c^2)} \right] \quad (27)$$

For example, if the LO coupler has a 3° phase error and the DC references at the modulating signals are accurate to ± 40 mV with a 1 V_{PP} modulating signal, and the amplitude ratio of the modulating signals is about 1.1, then the vector state amplitude error is 0.24 dB; the vector state phase error is 4.4°; the undesired sideband suppression is -25.3 dB; the carrier suppression is -24.7 dB. To verify the effects of various error terms on the undesired sideband suppression and carrier suppression, an SSB evaluation can be used. To verify the effects of these error terms on $a(t)$ and $\varphi(t)$, the DC static evaluation can be employed with Equations (28) and (29).

Carrier
Vector
Amplitude =

$$10 \log \left[\frac{D_{m2}^2 + 2 K_m K_c D_{m1} \sin \alpha + K_m^2 K_c^2 D_{m1}^2}{\frac{1}{2} (1 + 2 K_m K_c \cos(\alpha - \beta) + K_m^2 K_c^2)} \right] \quad (28)$$

Carrier
Vector
Phase =

$$\tan^{-1} \left[\frac{K_m K_c D_{m1} \cos \alpha}{D_{m2} + K_m K_c D_{m1} \sin \alpha} \right] \quad (29)$$

Since the DC static measurements are made at the LO frequency, undesired carrier feed-thru will affect the measurement of $a(\theta)$ and $\varphi(\theta)$. The undesired carrier feed-thru effectively adds as a constant vector, with an amplitude (in dB) found in Equation (28) and a phase found in Equation (29), to the vector defined by $a(\theta)$ and $\varphi(\theta)$ (Figure 10).

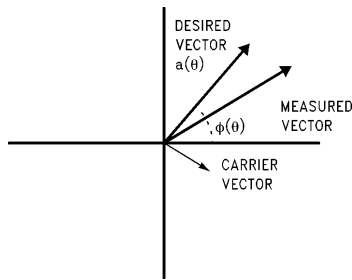

TL/W/11877-25

FIGURE 10. Effect of Carrier Vector on a Measured Vector for DC Static Evaluation

For the example given above, a carrier transmission vector with an amplitude of 0.5 dB and a phase of 3.3° are included as an error source in a DC static measurement of $a(\theta)$ and $\varphi(\theta)$. The carrier transmission vector offsets the center of the circle traced in a DC static measurement. This constant vector is subtracted from the measurement to obtain $a(\theta)$ and $\varphi(\theta)$. The remaining errors in this vector are $a(\theta)_{\text{error}}$ and $\varphi(\theta)_{\text{error}}$.

Note 3: Most integrated quadrature modulators can be used differentially or single-endedly. Single-ended operation eliminates the reflections of the in-phase and quadrature input signals at a performance cost.

Time Dependent Phase Error

One other source of phase error that can be introduced to the quadrature modulator is a time dependent phase error associated with the slew rate limitations of the modulating signals. As the peak-to-peak voltage of the modulating signal increases, the resistive and capacitive characteristics of the device prevent full signal charge development. This results in a time dependent phase delay with a maximum phase error occurring at the peak modulating voltage. The effect of this error can be reduced by reducing the peak-to-peak modulating voltage.

Modulated Carrier Harmonics

One source of modulated carrier harmonics is the internal input transistors at the LO input of the quadrature modulator that operate in a switching fashion. The quadrature modulator is effectively multiplying a square wave for the LO by the modulating signals. Equation (30) represents a square wave where A is the amplitude and ω_o is the fundamental frequency.

$$f(t) = \frac{4A}{\pi} \left(\sin \omega_o t + \frac{1}{3} \sin 3\omega_o t + \frac{1}{5} \sin 5\omega_o t + \dots \right) \quad (30)$$

Any signal that is modulated onto the carrier will also be modulated onto the 3rd carrier harmonic and the 5th carrier harmonic at reduced power levels. Most often, the band limiting characteristics of the quadrature modulator prevent the exit of these signals from the device. If this is not the case, the signal about the 3rd and 5th harmonics must be filtered out in the radio system.

Nonlinear Impairments

Nonlinear impairment is associated with the modulating signals. Ideally, the modulating signals operate transistors in a linear region. Deviations from this linear region arise during single ended operation of the modulating signal inputs and from overdriving the modulating signal voltages (Note 3). For a memoryless two-port network with weak nonlinearity, the output can be represented by a power series of the input as

$$v_o = k_1 v_i + k_2 v_i^2 + k_3 v_i^3 + \dots \quad (31)$$

For a sinusoidal input,

$$v_i = A \cos \omega_1 t \quad (32)$$

the output is

$$v_o = \frac{1}{2} k_2 A^2 + \left(k_1 A + \frac{3}{4} k_3 A^3 \right) \cos \omega_1 t + \frac{1}{2} k_2 A^2 \cos 2\omega_1 t + \frac{1}{4} k_3 A^3 \cos 3\omega_1 t \quad (33) [7]$$

Equation (33) represents the harmonics of a sinusoidal modulating signal generated by nonlinearities. This means that not only is the desired modulating signal up-converted but the harmonics of this modulating signal are up-converted as well. These harmonics are kept to a minimum by operating the modulating signal ports differentially and within the recommended peak-to-peak voltage.

CONCLUSION

The quadrature modulator is a universal modulator that is used in contemporary digital wireless communications. Evaluating and utilizing quadrature modulators requires an understanding of the fundamental operation of the quadrature modulator along with the performance constraints. The error terms that influence the quadrature modulator are interrelated and can be modeled by equations to predict performance. Other features of the quadrature modulator have been discussed to guide a user in applying the quadrature modulator in his or her radio.

ACKNOWLEDGMENTS

Special thanks goes to D. Fague, B. Madsen, and D. Bien for their critique and contributions to this article.

REFERENCES

- [1] P. Gray and R. Meyer, *Analysis and Design of Analog Integrated Circuits*. John Wiley & Sons, 2nd ed., 1984.
- [2] D. E. Fague, "An Integrated Baseband Processor for Universal Personal Communications Applications", *Proceedings from the Third IEEE International Symposium on Personal, Indoor and Mobile Radio Communications*, October, 1992, Boston, MA.
- [3] J. W. Archer, J. Granlund, and R. E. Mauzy, "A Broad-Band UHF Mixer Exhibiting High Image Rejection over a Multidecade Baseband Frequency Range", *IEEE J. Solid-State Circuits*, vol. SC-3, pp. 365-373, Dec. 1968.
- [4] D. E. Norton, S. A. Massa, and P. O'Donovan, "I and Q Modulators for Cellular Communications Systems", *Microwave Journal*, pp. 63-80, Oct. 1991.
- [5] S Pasupathy, "Minimum Shift Keying: A Spectrally Efficient Modulation", *IEEE Communications Magazine*, pp. 14-22, 1979.
- [6] A. Papoulis, *Circuits and Systems, A Modern Approach*. Holt, Rinehart and Winston, Inc., New York, 1980.
- [7] A. Dao, "Integrated LNA/Mixer Basics", National Semiconductor Application Note, AN-884, April, 1993.

LIFE SUPPORT POLICY

NATIONAL'S PRODUCTS ARE NOT AUTHORIZED FOR USE AS CRITICAL COMPONENTS IN LIFE SUPPORT DEVICES OR SYSTEMS WITHOUT THE EXPRESS WRITTEN APPROVAL OF THE PRESIDENT OF NATIONAL SEMICONDUCTOR CORPORATION. As used herein:

- 1. Life support devices or systems are devices or systems which, (a) are intended for surgical implant into the body, or (b) support or sustain life, and whose failure to perform, when properly used in accordance with instructions for use provided in the labeling, can be reasonably expected to result in a significant injury to the user.
- 2. A critical component is any component of a life support device or system whose failure to perform can be reasonably expected to cause the failure of the life support device or system, or to affect its safety or effectiveness.



National Semiconductor Corporation
 2900 Semiconductor Drive
 P.O. Box 58090
 Santa Clara, CA 95052-8090
 Tel: 1(800) 272-9959
 TWX: (910) 339-9240

National Semiconductor GmbH
 Livry-Gargan-Str. 10
 D-82256 Fürstenfeldbruck
 Germany
 Tel: (81-41) 35-0
 Telex: 527849
 Fax: (81-41) 35-1

National Semiconductor Japan Ltd.
 Sumitomo Chemical
 Engineering Center
 Bldg, 7F
 1-7-1, Nakase, Mihama-Ku
 Chiba-City,
 Ciba Prefecture 261
 Tel: (043) 299-2300
 Fax: (043) 299-2500

National Semiconductor Hong Kong Ltd.
 13th Floor, Straight Block,
 Ocean Centre, 5 Canton Rd.
 Tsimshatsui, Kowloon
 Hong Kong
 Tel: (852) 2737-1600
 Fax: (852) 2736-9960

National Semicondutores Do Brazil Ltda.
 Rue Deputado Lacorda Franco
 120-3A
 Sao Paulo-SP
 Brazil 05418-000
 Tel: (55-11) 212-5066
 Telex: 391-1131931 NSBR BR
 Fax: (55-11) 212-1181

National Semiconductor (Australia) Pty, Ltd.
 Building 16
 Business Park Drive
 Monash Business Park
 Nottinghill, Melbourne
 Victoria 3168 Australia
 Tel: (3) 558-9999
 Fax: (3) 558-9998

National does not assume any responsibility for use of any circuitry described, no circuit patent licenses are implied and National reserves the right at any time without notice to change said circuitry and specifications.